



## RVT28AETNWC00

### LCD TFT Datasheet

Rev.2.1

2016-02-09

ITEM	CONTENTS	UNIT
LCD Type	TFT/Transmissive/Normally white	/
Size	2.83	Inch
Viewing Direction	6:00 (without image inversion)	O' Clock
Gray Scale Inversion Direction	12:00	O' Clock
LCM (W × H × D)	50.20 x 69.30 x 4.80	mm3
Active Area (W × H)	43.20 × 57.60	mm2
Dot Pitch (W × H)	0.18 × 0.18	mm2
Number of Dots	240 x (RGB) × 320	/
Driver IC	ILI9341	/
Backlight Type	4 LEDs	/
Surface Luminance	255	cd/m2
Interface Type	CPU/RGB/SPI	/
Color Depth	65K/262K	/
Pixel Arrangement	RGB Vertical Stripe	/
Surface Treatment	Clear	
Input Voltage	2.8	V
With/Without TSP	Projected Capacitive Touch Panel	/
Weight	28.70	g

**Note 1:** RoHS compliant

**Note 2:** LCM weight tolerance: ± 5%.

## REVISION RECORD

REVNO.	REVDATE	CONTENTS	REMARKS
1.0	2015-03-13	Initial Release	
1.1	2015-06-24	Update viewing direction	
1.2	2016-10-13	Added Inspection Standards	
2.0	2016-10-13	New PCT Controller	
2.1	2017-02-09	Updated gasket dimension	

## CONTENTS

REVISION RECORD.....	2
CONTENTS .....	2
1 MODULE CLASSIFICATION INFORMATION .....	4
2 MODULE DRAWING .....	4
3 ABSOLUTE MAXIMUM RATINGS.....	5
4 ELECTRICAL CHARACTERISTICS.....	5
5 BACKLIGHT CHARACTERISTICS .....	5
6 ELECTRO-OPTICAL CHARACTERISTICS .....	6
7 INTERFACE DESCRIPTION .....	8
8 LCD TIMING CHARACTERISTICS .....	9
8.1 Display Parallel 18/16/9/8-bit Interface Timing Characteristics(8080-I system) .....	9
8.2 Display Parallel 18/16/9/8-bit Interface Timing Characteristics (8080-II system) .....	11
8.3 Display Serial Interface Timing Characteristics (3-line SPI system).....	13
8.4 Display Serial Interface Timing Characteristics (4-line SPI system).....	14
8.5 Parallel 18/16/6-bit RGB Interface Timing Characteristics .....	15
9 INITIAL CODE .....	16
10 CAPACITIVE TOUCH SCREEN PANEL SPECIFICATIONS .....	18
10.1 Mechanical characteristics .....	18
10.2 Electrical characteristics .....	18
10.3 Interface description .....	18
10.4 Interface timing characteristics.....	19
10.5 CTP timing configuration .....	19
10.6 Communication of the I2C interface with Host.....	20
10.7 Touch data read protocol.....	20
10.8 Data description .....	20
10.9 Interrupt Trigger Mode .....	22
11 INSPECTION .....	23
11.1 Inspection condition.....	23
11.2 Inspection standard.....	24
12 RELIABILITY TEST.....	27
13 LEGAL INFORMATION.....	28

## 1 MODULE CLASSIFICATION INFORMATION

RV	T	28	A	E	T	N	W	C	∅∅
1.	2.	3.	4.	5.	6.	7.	8.	9.	10.

1.	<b>BRAND</b>	RV – Riverdi
2.	<b>PRODUCT TYPE</b>	<b>T – TFT Standard</b> F – TFT Custom
3.	<b>DISPLAY SIZE</b>	<b>28 – 2.83”</b> 35 – 3.5” 43 – 4.3” 70 – 7.0”
4.	<b>MODEL SERIAL NO.</b>	<b>A (A-Z)</b>
5.	<b>RESOLUTION</b>	<b>E– 240x320 px</b>
6.	<b>INTERFACE</b>	<b>T – TFT LCD, RGB</b> L – TFT LCD, LVDS S – TFT + Controller SSD1963 F – TFT + Controller FT801
7.	<b>FRAME</b>	<b>N – No Frame</b> F – Mounting Frame
8.	<b>BACKLIGHT TYPE</b>	<b>W – LED White</b>
9.	<b>TOUCH PANEL</b>	<b>N – No Touch Panel</b> <b>R – Resistive Touch Panel</b> <b>C – Capacitive Touch Panel</b>
10.	<b>VERSION</b>	<b>00(00-99)</b>

TFT PINOUT	
1	LEDK
2	LEDA1
3	LEDA2
4	LEDA3
5	LEDA4
6	IM0
7	IM1
8	IM2
9	IM3
10	RESET
11	VSYNC
12	HSYNC
13	DOTCLK
14	DE
15	DB17
16	DB16
17	DB15
18	DB14
19	DB13
20	DB12
21	DB11
22	DB10
23	DB9
24	DB8
25	DB7
26	DB6
27	DB5
28	DB4
29	DB3
30	DB2
31	DB1
32	DB0
33	SDO
34	SDI
35	RD
36	WRX(D/CX)
37	D/CX(SCL)
38	CSX
39	TE
40	VDDI
41	VDDI
42	VCI
43	GND
44	NC
45	NC
46	NC
47	NC
48	GND
49	GND
50	GND

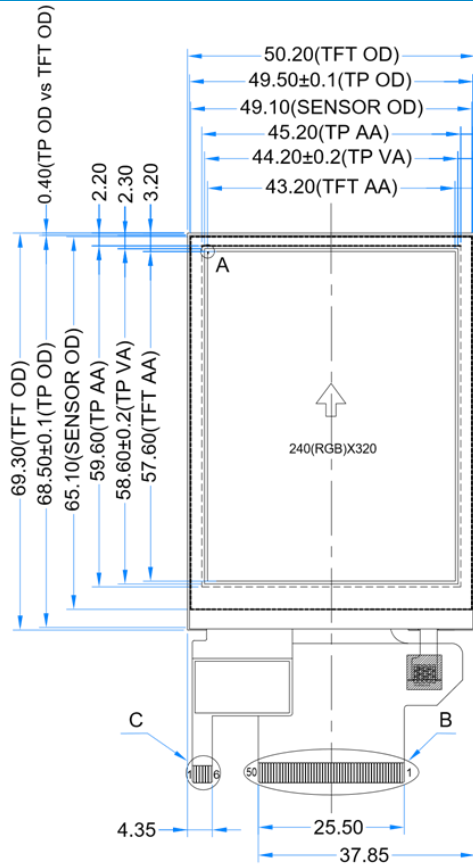

NOTES:

1. DISPLAY TYPE: TFT, TRANSMISSIVE, NORMALLY WHITE
2. 2.83 INCH CAPACITIVE TOUCH PANEL
3. VIEWING DIRECTION: 6 O'CLOCK
4. OPERATION VOLTAGE: VDD= 2.8V
5. IC CONTROLLER: ILI9341
6. CTP IC DRIVER: FT6236
7. CTP RESOLUTION 240x320 DOTS
8. CTP MULTIFINGER: UP TO 2- TOUCH GESTURE
9. LED BACKLIGHT: 4-LED WHITE
10. SURFACE LUMINANCE: 255 cd/m<sup>2</sup>
11. OPERATING TEMP: -20°C ~ +70°C
12. STORAGE TEMP: -30°C ~ +80°C
13. GENERAL TOLERANCE: ±0.20
14. RoHS COMPLIANT

DETAIL B  
SCALE 2:1

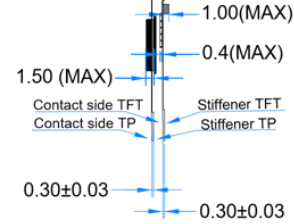
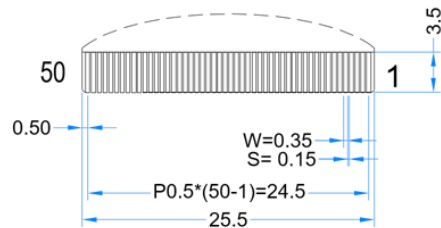

DETAIL A  
SCALE 20:1

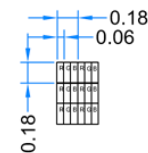

DETAIL C  
SCALE 4:1

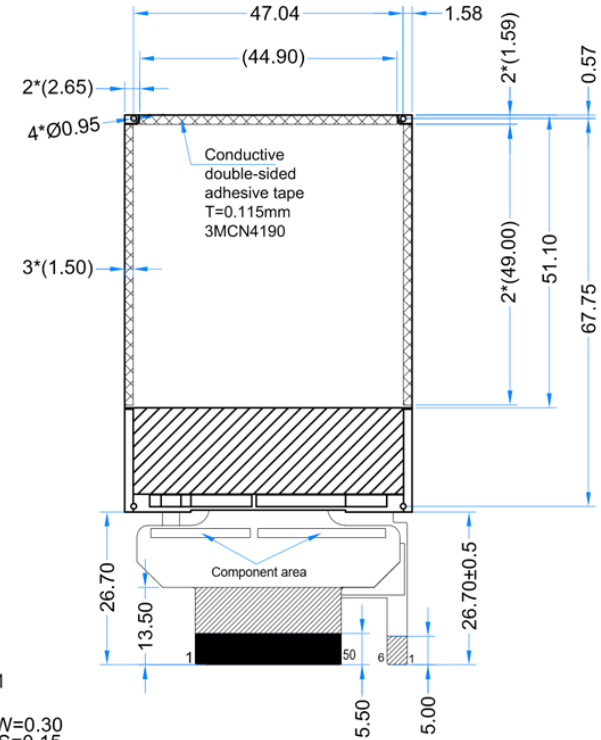
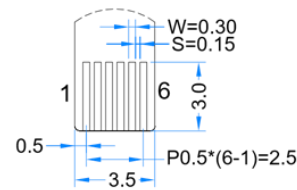

INTERNAL BACKLIGHT CIRCUIT DIAGRAM

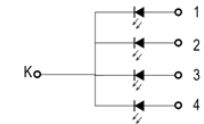

CTP PINOUT

CTP PINOUT	
1	TP_VDD
2	TP_RES
3	TP_INT
4	TP_SDA
5	TP_SCK
6	TP_GND

CUSTOMER		DATE	2017/02/09
DRAWN	SCALE 1:1	TITLE	
DFTG CHK	UNIT mm	RVT28AETNWC00	
ENGR CHK		MODEL	
APPROVAL		DWG NO	
		Rev.1.0	PAGE 1/1



### 3 ABSOLUTE MAXIMUM RATINGS

PARAMETER	SYMBOL	MIN	MAX	UNIT
Supply Voltage For LCD Logic	VDD	-0.3	4.6	V
Logic signal voltage	VDD	-0.3	4.6	V
Operating Temperature	T <sub>OP</sub>	-20	70	°C
Storage Temperature	T <sub>ST</sub>	-30	80	°C
Humidity	RH	-	90% (Max 60°C)	RH

### 4 ELECTRICAL CHARACTERISTICS

PARAMETER	SYMBOL	MIN	TYP	MAX	UNIT
Power Supply Voltage For LCD Logic	VDD	2.5	2.8	3.3	V
Supply Voltage For CTP Logic	VDD	2.8	3.0	3.3	V
Input Current	IDD	-	TBD	-	mA
Input Voltage ' H ' level	V <sub>IH</sub>	0.7VDD	-	VDD	V
Input Voltage ' L ' level	V <sub>IL</sub>	GND	-	0.3VDD	V
Output Voltage ' H ' level	V <sub>oH</sub>	0.8VDD	-	VDD	V
Output Voltage ' L ' level	V <sub>oL</sub>	GND	-	0.2VDD	V

### 5 BACKLIGHT CHARACTERISTICS

ITEM	SYMBOL	MIN	TYP	MAX	UNIT
Voltage for LED backlight	V <sub>f</sub>	-	3.2	3.4	V
Current for LED backlight	I <sub>f</sub>	-	80	-	mA
Power consumption	W <sub>BL</sub>	-	256	-	mW
LED Life Time	-	30000	40000	-	Hrs

**Note:**

1. The LED life time is defined as the module brightness decrease to 50% original brightness at Ta=25°C, 60%RH ±5 %.
2. The life time of LED will be reduced if LED is driven by high current, high ambient temperature and humidity conditions.
3. Typical operating life time is an estimated data.
4. Permanent damage to the device may occur if maximum values are exceeded or reverse voltage is loaded. Functional operation should be restricted to the conditions described under normal operating conditions.

## 6 ELECTRO-OPTICAL CHARACTERISTICS

ITEM	SYMBOL	CONDITION	MIN	TYP	MAX	UNIT	REMARK	NOTE
Response Time	Tr+Tf	$\theta=0^\circ$ $\phi=0^\circ$ Ta=25	-	25	30	ms	Figure 1	4
Contrast Ratio	Cr		-	500	-	---	Figure 2	1
Luminance Uniformity	$\delta$ WHITE		80	90	-	%	Figure 2	3
Surface Luminance	Lv		-	255	-	cd/m <sup>2</sup>	Figure 2	2
Viewing Angle Range	$\theta$	$\phi = 90^\circ$ $\phi = 270^\circ$ $\phi = 0^\circ$ $\phi = 180^\circ$	-	70	-	deg	Figure 3	6
			-	57	-	deg	Figure 3	
			-	70	-	deg	Figure 3	
			-	70	-	deg	Figure 3	
CIE (x, y) Chromaticity	Red	$\theta=0^\circ$ $\phi=0^\circ$ Ta=25	-	0.6368	-	Figure 2	5	
			-	0.3329	-			
	Green		-	0.3397	-			
			-	0.6138	-			
	Blue		-	0.1433	-			
			-	0.0807	-			
White	-	0.2886	-					
	-	0.3194	-					
NTSC	-	S	-	55	67	-	%	-

**Note 1.** Contrast Ratio(CR) is defined mathematically as below, for more information see Figure 1

$$\text{Contrast Ratio} = \frac{\text{Average Surface Luminance with all white pixels (P1, P2, P3, P4, P5)}}{\text{Average Surface Luminance with all black pixels (P1, P2, P3, P4, P5)}}$$

**Note 2.** Surface luminance is the LCD surface from the surface with all pixels displaying white. For more information, see Figure 2.

Lv = Average Surface Luminance with all white pixels (P1, P2, P3, P4, P5)

**Note 3.** The uniformity in surface luminance  $\delta$  WHITE is determined by measuring luminance at each test position 1 through 5, and then dividing the maximum luminance of 5 points luminance by minimum luminance of 5 points luminance. For more information, see Figure 2.

$$\delta \text{ WHITE} = \frac{\text{Minimum Surface Luminance with all white pixels (P1, P2, P3, P4, P5)}}{\text{Maximum Surface Luminance with all white pixels (P1, P2, P3, P4, P5)}}$$

**Note 4.** Response time is the time required for the display to transition from white to black (Rise Time, Tr) and from black to white (Decay Time, Tf). For additional information see FIG 1. The test equipment is Autronic-Melchers's ConoScope series.

**Note 5.** CIE (x, y) chromaticity, the x, y value is determined by measuring luminance at each test position 1 through 5, and then make average value.

**Note 6.** Viewing angle is the angle at which the contrast ratio is greater than 2. For TFT module the contrast ratio is greater than 10. The angles are determined for the horizontal or x axis and the vertical or y axis with respect to the z axis which is normal to the LCD surface. For more information, see Figure 3.

**Note 7.** For viewing angle and response time testing, the testing data is based on Autronic-Melchers's ConoScope series. Instruments for Contrast Ratio, Surface Luminance, Luminance Uniformity, CIE the test data is based on TOPCON's BM-5 photo detector.

Figure 1. The definition of response time

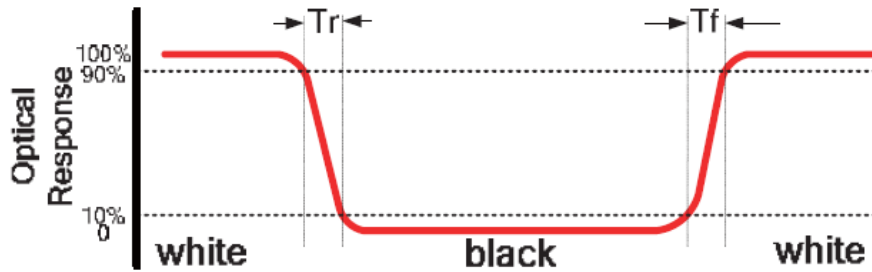

Figure 2. Measuring method for Contrast ratio, surface luminance, Luminance uniformity, CIE (x, y) chromaticity

A : 5 mm  
 B : 5 mm  
 H, V : Active Area  
 Light spot size  $\varnothing=5\text{mm}$ , 500mm distance from the LCD surface to detector lens  
 measurement instrument is TOPCON's luminance meter BM-5

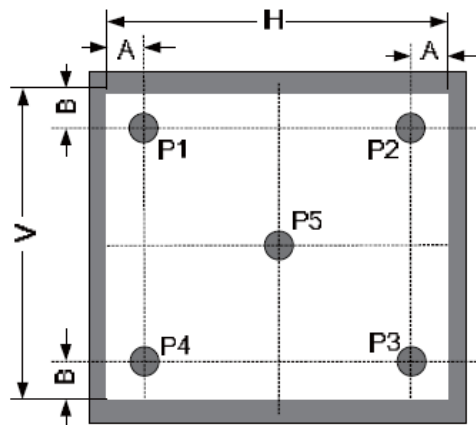
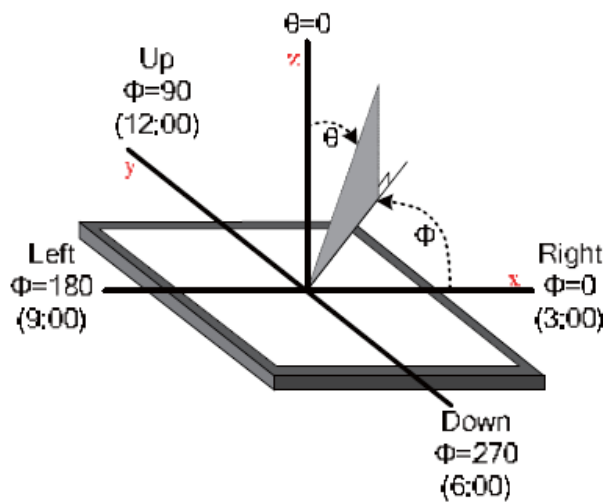

Figure 3. The definition of viewing angle





## 7 INTERFACE DESCRIPTION

PIN NO.	SYMBOL	DESCRIPTION	REMARK
1	LEDK	Cathode Of LED Backlight	
2	LEDA1	Anode No.1 for LED backlighting	
3	LEDA2	Anode No.2 for LED backlighting	
4	LEDA3	Anode No.3 for LED backlighting	
5	LEDA4	Anode No.4for LED backlighting	
6	IM0	Select Interface Mode	Note1
7	IM1		
8	IM2		
9	IM3		
10	RESET	Reset pin	
11	VSYNC	Frame Synchronizing Signal For RGB Interface	
12	HSYNC	Line Synchronizing Signal For RGB Interface	
13	DOTCLK	Dot Clock Signal For RGB Interface	
14	DE	Data Enable Signal For RGB Interface	
15- 32	DB17-DB0	DATA BUS	
33	SDO	Serial Output Signal	
34	SDI	Serial Input Signal	
35	RD	Read execution control pin	
36	WRX(D/CX)	Write execution control pin; Serial Register select s Signal	
37	D/CX(SCL)	Register select signal; Serial Interface Clock	
38	CSX	Chip Select Signal	
39	TE	Tearing effect out pin synchronize MPU to frame writing	
40	VDDI	Power Supply: + 2.8V	
41	VDDI	Power Supply: +2.8V	
42	VCI	Logic power, provide with 2.8V	
43	GND	Power Ground	
44	NC	No Connection	
45	NC	No Connection	
46	NC	No Connection	
47	NC	No Connection	
48	GND	Power Ground	
49	GND	Power Ground	
50	GND	Power Ground	

**Note1:** (pins 6-9)

IM 3	IM 2	IM 1	IM 0	MCU-Interface Mode	REGISTER/CONTENT	GRAM
0	0	0	0	8080 MCU 8-bit bus interface I	D[7:0]	D[7:0], WRX, RDX, CSX, D/CX
0	0	0	1	8080 MCU 16-bit bus interface I	D[7:0]	D[15:0], WRX, RDX, CSX, D/CX
0	0	1	0	8080 MCU 9-bit bus interface I	D[7:0]	D[8:0], WRX, RDX, CSX, D/CX
0	0	1	1	8080 MCU 18-bit bus interface I	D[7:0]	D[17:0], WRX, RDX, CSX, D/CX
0	1	0	1	3-wire 9-bit data serial interface I	SCL, SDA, CSX	
0	1	1	0	4-wire 8-bit data serial interface I	SCL, SDA, D/CX, CSX	
1	0	0	0	8080 MCU 16-bit bus interface II	D[8:1]	D[17:10], D[8:1], WRX, RDX, CSX, D/CX
1	0	0	1	8080 MCU 8-bit bus interface II	D[17:10]	D[17:10], WRX, RDX, CSX, D/CX
1	0	1	0	8080 MCU 18-bit bus interface II	D[8:1]	D[17:0], WRX, RDX, CSX, D/CX
1	0	1	1	8080 MCU 9-bit bus interface II	D[17:10]	D[17:9], WRX, RDX, CSX, D/CX
1	1	0	1	3-wire 9-bit data serial interface II	SCL, SDA, SDO, CSX	
1	1	1	0	4-wire 8-bit data serial interface II	SCL, SDA, D/CX, SDO, CSX	

## 8 LCD TIMING CHARACTERISTICS

### 8.1 Display Parallel 18/16/9/8-bit Interface Timing Characteristics (8080-I system)

Figure 4 Interface Timing chart

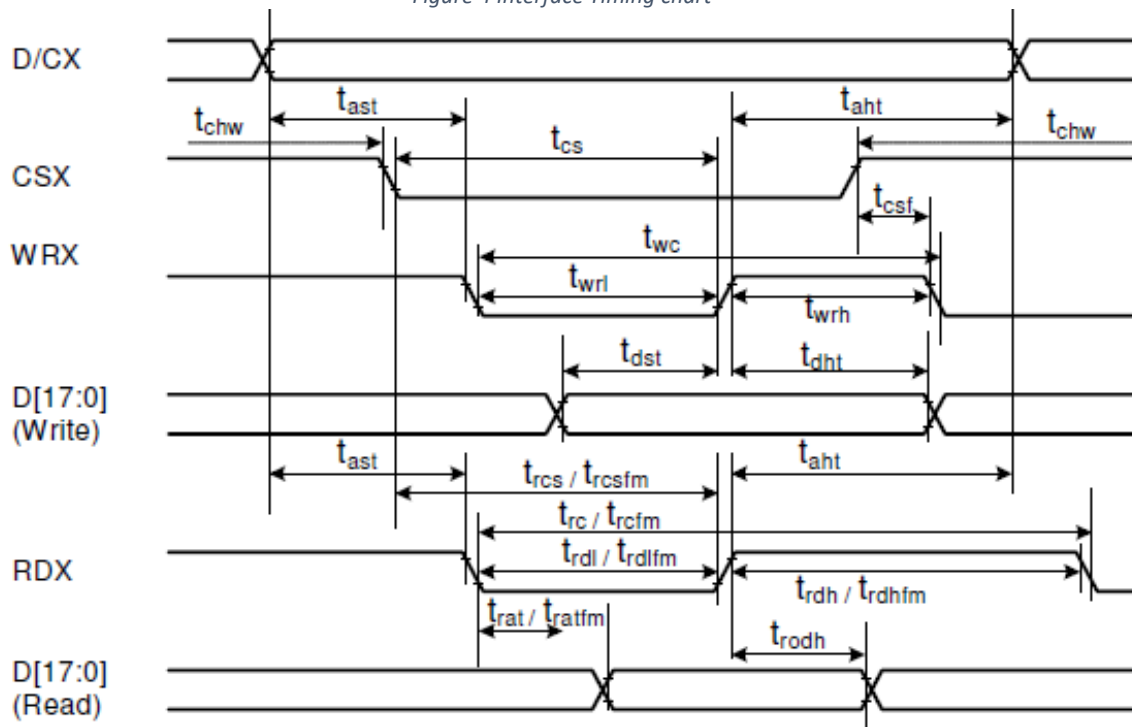

SIGNAL	SYMBOL	PARAMETER	MIN	MAX	UNIT	CONDITION
DCX	tast	Address setup time	0	-	ns	
	taht	Address hold time (Wrote/Read)	0	-	ns	
CSX	tchw	CSX "H" pulse width	0	-	ns	
	tcs	Chip Select setup time (Write)	15	-	ns	
	trcs	Chip Select setup time (Read IT)	45	-	ns	
	trcsfm	Chip Select setup time (Read FM)	355	-	ns	
	tcsf	Chip Select setup time (Write/Read)	10	-	ns	
WRX	twc	Write Cycle	66	-	ns	
	twrh	Write Control pulse H duration	15	-	ns	
	twrl	Write Control pulse L duration	15	-	ns	
RDX(FM)	trc	Write Cycle(FM)	450	-	ns	
	trdh	Read Control H duration (FM)	90	-	ns	
	trdl	Read Control L duration (FM)	355	-	ns	
RDX(ID)	trc	Read Cycle (ID)	160	-	ns	
	trdh	Read Control pulse H duration	90	-	ns	
	trdl	Read Control pulse L duration	45	-	ns	
D[17:0] D[17:10] D[8:1], D[17:10], D[17:9]	tdst	Write data setup time	10	-	ns	For max CL= 30pF For min CL= 8pF
	tdht	Write data hold time	10	-	ns	
	trat	Read access time	-	40	ns	
	tratfm	Read access time	-	340	ns	
	trod	Read output disable time	20	80	ns	

**Note1:** Ta= -30 to 70°C, VDDI=1.65V to 3.3V, VCI=2.5V to 3.3V, VSS=0V.

**Note2:** Logic high and low levels are specified as 30% and 70% of VDDI for Input signals.

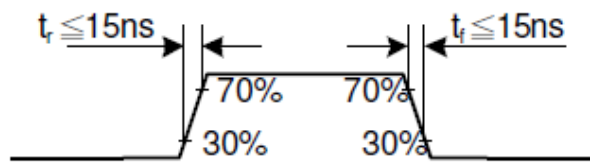
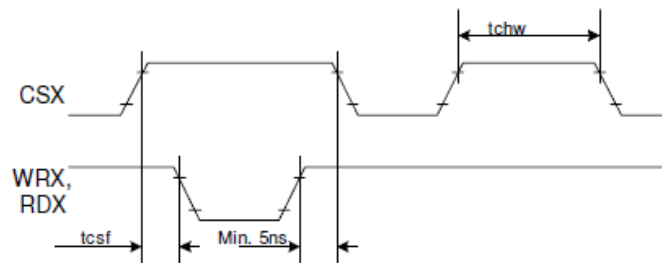

Figure 5 CSX timing



Note: Logic high and low levels are specified as 30% and 70% of VDD for Input signals.

The details of controller command and communications are included in ILI9341 datasheet.

Figure 6 Writing to read or read to write timings

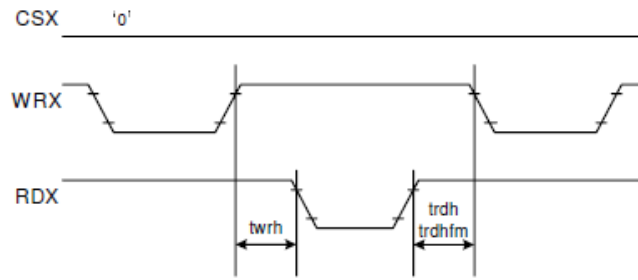

Note: Logic high and low levels are specified as 30% and 70% of VDD for Input signals.

The details of controller command and communications are included in ILI9341 datasheet.

8.2 Display Parallel 18/16/9/8-bit Interface Timing Characteristics (8080-II system)

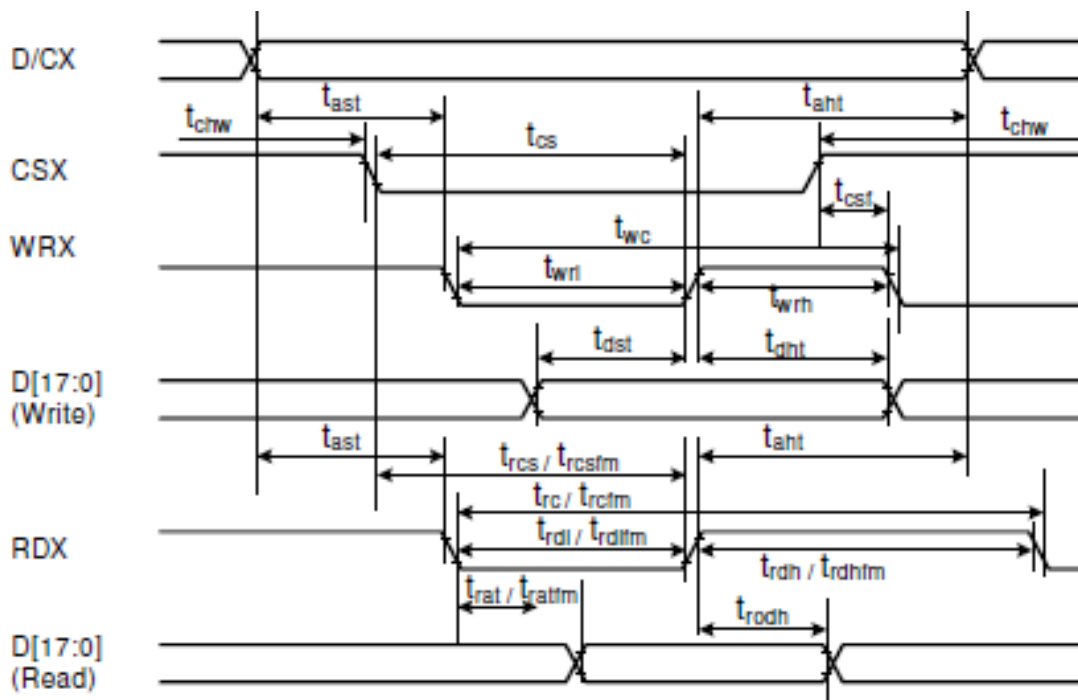

SIGNAL	SYMBOL	PARAMETER	MIN	MAX	UNIT	CONDITION
DCX	tast	Address setup time	0	-	ns	
	taht	Address hold time (Wrote/Read)	0	-	ns	
CSX	tchw	CSX "H" pulse width	0	-	ns	
	tcs	Chip Select setup time (Write)	15	-	ns	
	trcs	Chip Select setup time (Read IT)	45	-	ns	
	trcsfm	Chip Select setup time (Read FM)	355	-	ns	
WRX	tcsf	Chip Select setup time (Write/Read)	10	-	ns	
	twc	Write Cycle	66	-	ns	
	twrh	Write Control pulse H duration	15	-	ns	
	twrl	Write Control pulse L duration	15	-	ns	
	trc	Write Cycle(FM)	450	-	ns	

RDX(FM)	trdh	Read Control H duration (FM)	90	-	ns	
	trdl	Read Control L duration (FM)	355	-	ns	
RDX(ID)	trc	Read Cycle (ID)	160		ns	
	trdh	Read Control pulse H duration	90	-	ns	
	trdl	Read Control pulse L duration	45	-	ns	
D[17:0] D[17:10] D[8:1], D[17:10], D[17:9]	tdst	Write data setup time	10	-	ns	For max CL= 30pF For min CL= 8pF
	tdht	Write data hold time	10	-	ns	
	trat	Read access time	-	40	ns	
	tratfm	Read access time	-	340	ns	
	trout	Read output disable time	20	80	ns	

**Note1:** Ta= -30 to 70°C, VDDI=1.65V to 3.3V, VCI=2.5V to 3.3V, VSS=0V.

**Note2:** Logic high and low levels are specified as 30% and 70% of VDD for Input signals.

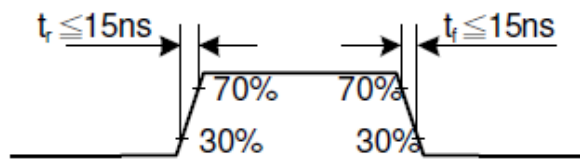
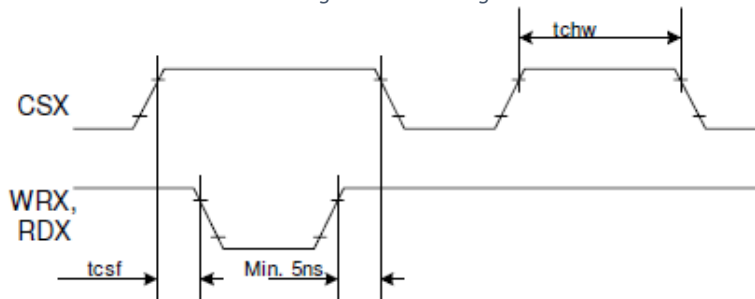
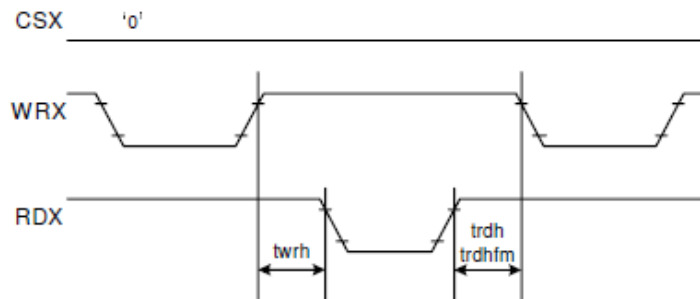

Figure 7 CSX timing



Note: Logic high and low levels are specified as 30% and 70% of VDD for Input signals.

Figure 8 Writing to read or read to write timings



Note: Logic high and low levels are specified as 30% and 70% of VDD for Input signals.

The details of controller command and communications are included in ILI9341 datasheet.

8.3 Display Serial Interface Timing Characteristics (3-line SPI system)

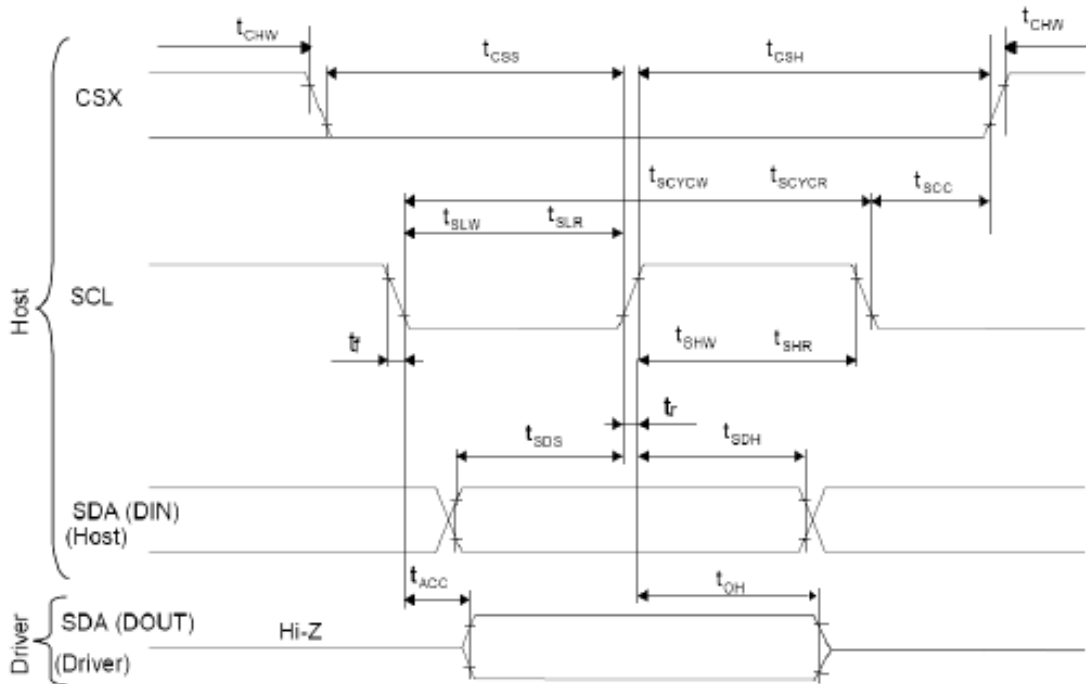

SIGNAL	SYMBOL	PARAMETER	MIN	MAX	UNIT	CONDITION
SCL	tscycw	Serial Clock Cycle (Write)	100	-	ns	
	tshw	SCL "H" Pulse Width(Write)	40	-	ns	
	tslw	SCL "L" Pulse Width(Write)	40	-	ns	
	tscycr	Serial Clock Cycle (Read)	150	-	ns	
	tshr	SCL "H" Pulse Width(Read)	60	-	ns	
	tslr	SCL "L" Pulse Width(Read)	60	-	ns	
SDA/SDI (Input)	tsds	Data setup time (Write)	30	-	ns	
	tsdh	Data hold time (Write)	30	-	ns	
SDA/SDI (Output)	tacc	Access time (Read)	10	-	ns	
	toh	Output disable time (Read)	10	50	ns	
CSX	tsc	SCL-CSX	20	-	ns	
	tch	CSX "H" Pulse Width	40	-	ns	
	tcss	SCX-SCL Time	60	-	ns	
	tch		65	-	ns	

Note: Ta25°C, VDDI=1.65V to 3.3V, VCI=2.5V to 3.3V, AGND=VSS=0V.

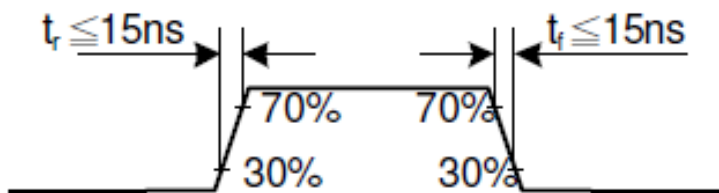

The details of controller command and communications are included in ILI9341 datasheet.

8.4 Display Serial Interface Timing Characteristics (4-line SPI system)

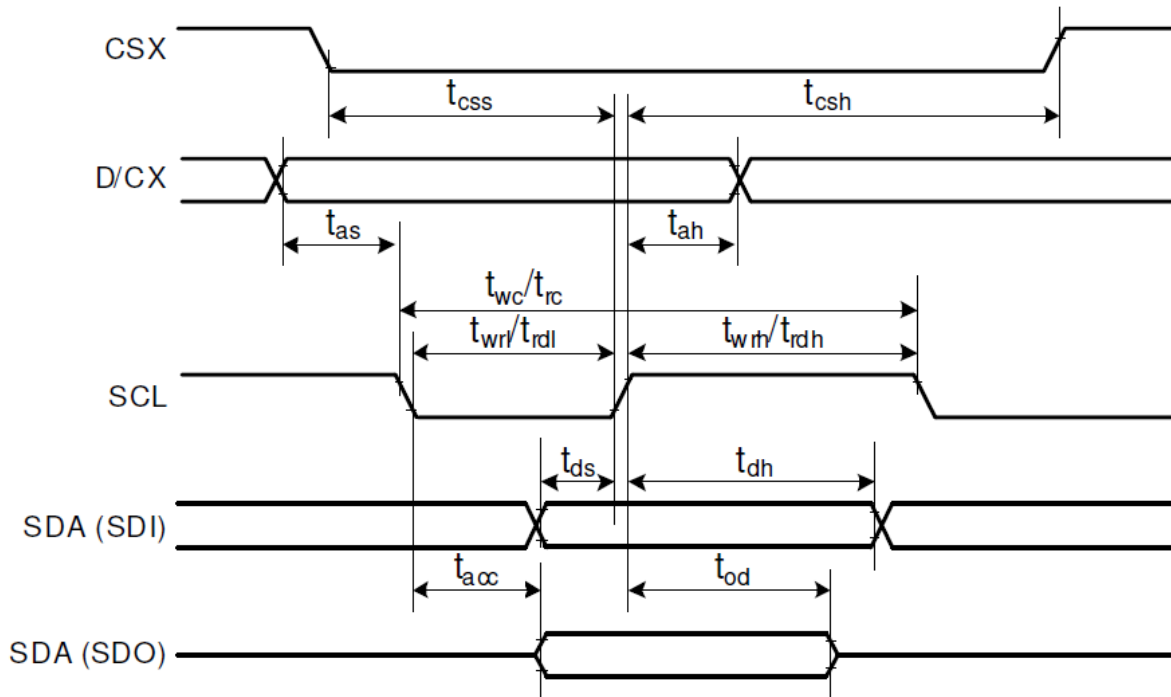

SIGNAL	SYMBOL	PARAMETER	MIN	MAX	UNIT	CONDITION
CSX	tcss	Serial Clock Cycle (Write)	40	-	ns	
	tcsh	SCL "H" Pulse Width(Write)	40	-	ns	
SCL	twc	Serial Clock Cycle (Read)	100	-	ns	
	twrh	SCL "H" Pulse Width(Read)	40	-	ns	
	twrl	SCL "L" Pulse Width(Read)	40	-	ns	
	trc	Serial clock cycle (Read)	150	-	ns	
	trdh	SCL "H" pulse width(Read)	60	-	ns	
	trdl	SCL "L" pulse width (Read)	60	-	ns	
D/CX	tas	D/CX setup time	10	-		
	tah	D/CX hold time (Write/ Read)	10	-		
SDA/SDI (Input)	tds	Data setup time (Write)	30	-	ns	
	tdh	Data hold time (Write)	30	-	ns	
SDA/SDI (Output)	tacc	Access time (Read)	10	-	ns	For max CL=30pF
	tod	Output disable time (Read)	10	50	ns	For min CL=8pF

Note: Ta25°C, VDDI=1.65V to 3.3V, VCI=2.5V to 3.3V, AGND=VSS=0V.

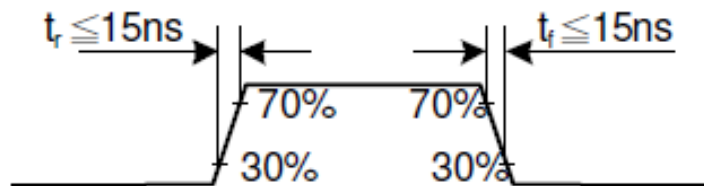

The details of controller command and communications are included in ILI9341 datasheet.

8.5 Parallel 18/16/6-bit RGB Interface Timing Characteristics

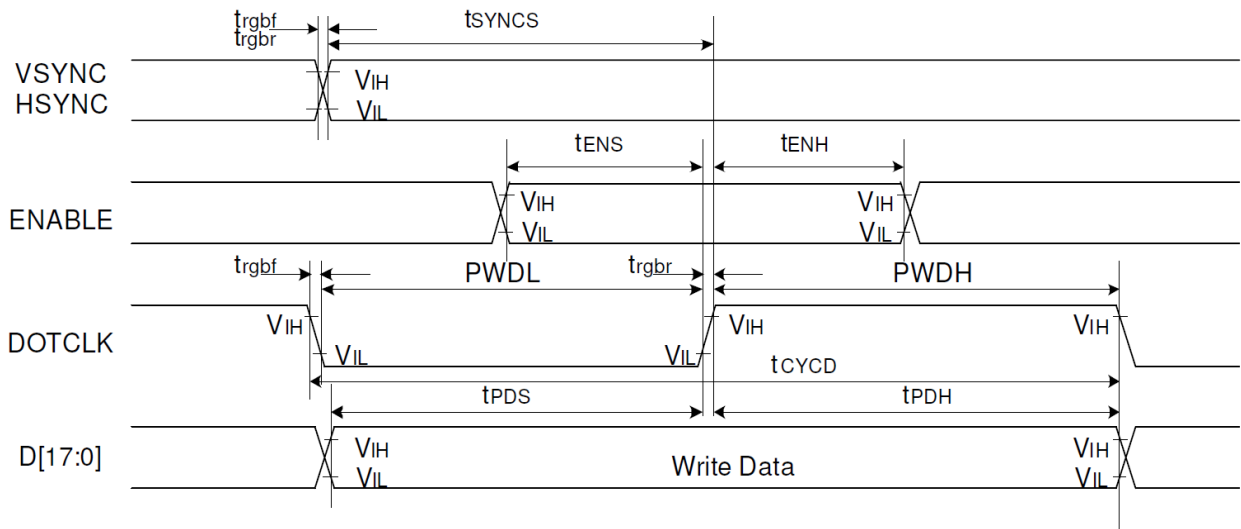

SIGNAL	SYMBOL	PARAMETER	MIN	MAX	UNIT	CONDITION	
VSYNC/HSYNC	$t_{SYNCS}$	VSYNC/HSYNC setup time	15	-	ns	18/16-bit bus RGB interface mode	
	$t_{SYNCH}$	VSYNC/HSYNC hold time	15	-	ns		
DE	$t_{ENS}$	DE setup time	5	-	ns		
	$t_{ENH}$	DE hold time	15	-	ns		
D[17:0]	$t_{POS}$	Data setup time	15	-	ns		
	$t_{PDH}$	Data hold time	15	-	ns		
DOTCLK	PWDH	DOTCLK high-level period	15	-	ns		
	PWDL	DOTCLK low-level period	15	-	ns		
	$t_{CYCD}$	DOTCLK cycle time	100				
	$t_{rgbr}, t_{rgbf}$	DOTCLK, HSYNC, VSYNC rise/fall time	-	15	ns		
VSYNC/HSYNC	$t_{SYNCS}$	VSYNC/HSYNC setup time	15	-	ns		6-bit bus RGB interface mode
	$t_{SYNCH}$	VSYNC/HSYNC hold time	15	-	ns		
DE	$t_{ENS}$	DE setup time	5	-	ns		
	$t_{ENH}$	DE hold time	15	-	ns		
D[17:0]	$t_{POS}$	Data setup time	15	-	ns		
	$t_{PDH}$	Data hold time	15	-	ns		
DOTCLK	PWDH	DOTCLK high-level period	15	-	ns		
	PWDL	DOTCLK low-level period	15	-	ns		
	$t_{CYCD}$	DOTCLK cycle time	100				
	$t_{rgbr}, t_{rgbf}$	DOTCLK, HSYNC, VSYNC rise/fall time	-	15	ns		

Note: Ta25°C, VDDI=1.65V to 3.3V, VCI=2.5V to 3.3V, AGND=VSS=0V.

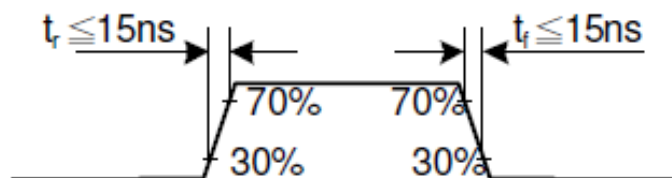

The details of controller command and communications are included in ILI9341 datasheet.



## 9 INITIAL CODE

```

// Hardware reset
GPIO_WriteBit(HW_Reset_Pin,1);
delay_ms(50);
GPIO_WriteBit(HW_Reset_Pin,0);
delay_ms(50);
GPIO_WriteBit(HW_Reset_Pin,1);
delay_ms(50);

LCD_WriteCommand(0x01); // Software reset
delay_ms(5);
LCD_WriteCommand(0x28); //Display off

//-----
LCD_WriteCommand(0xcf); //Power control B
LCD_WriteRAM(0x00);
LCD_WriteRAM(0x83);
LCD_WriteRAM(0x30);

LCD_WriteCommand(0xed); //Power on sequence control
LCD_WriteRAM(0x64);
LCD_WriteRAM(0x03);
LCD_WriteRAM(0x12);
LCD_WriteRAM(0x81);

LCD_WriteCommand(0xe8); //Driver timing control A
LCD_WriteRAM(0x85);
LCD_WriteRAM(0x01);
LCD_WriteRAM(0x79);

LCD_WriteCommand(0xcb); //Power control A
LCD_WriteRAM(0x39);
LCD_WriteRAM(0x2c);
LCD_WriteRAM(0x00);
LCD_WriteRAM(0x34);
LCD_WriteRAM(0x02);

LCD_WriteCommand(0xf7); //Pump ratio control
LCD_WriteRAM(0x20);

LCD_WriteCommand(0xea); //Driver timing control B
LCD_WriteRAM(0x00);
LCD_WriteRAM(0x00);

//-----Power Control-----
LCD_WriteCommand(0xc0); // Power Control 1
LCD_WriteRAM(0x26);

LCD_WriteCommand(0xc1); //Power Control 2
LCD_WriteRAM(0x11);

//-----VCOM setting -----
LCD_WriteCommand(0xc5); // VCOM Control
LCD_WriteRAM(0x35);
LCD_WriteRAM(0x3e);

LCD_WriteCommand(0xc7); // VCOM Control
LCD_WriteRAM(0xbe);

//-----Memory Access Control-----
LCD_WriteCommand(0x36); //Memory Access Control
LCD_WriteRAM(0x48); //my, mx, mv, ml, BGR, mh, 0.0

LCD_WriteCommand(0x3a); // Pixel Format set
LCD_WriteRAM(0x55); // 16bit /pixel

```

```

//----- Frame Rate-----
LCD_WriteCommand(0xb1); // Frame rate
LCD_WriteRAM(0x00);
LCD_WriteRAM(0x10);

//-----Gamma-----
LCD_WriteCommand(0xf2); // 3 Gamma Function Disable
LCD_WriteRAM(0x08);

LCD_WriteCommand(0x26); // Gamma set 4 gamma curve 01/02/04/08
LCD_WriteRAM(0x01);

LCD_WriteCommand(0xE0); // Positive Gamma Correction
LCD_WriteRAM(0x1f);
LCD_WriteRAM(0x1a);
LCD_WriteRAM(0x18);
LCD_WriteRAM(0x0a);
LCD_WriteRAM(0x0f);
LCD_WriteRAM(0x06);
LCD_WriteRAM(0x45);
LCD_WriteRAM(0x87);
LCD_WriteRAM(0x32);
LCD_WriteRAM(0x0a);
LCD_WriteRAM(0x07);
LCD_WriteRAM(0x02);
LCD_WriteRAM(0x07);
LCD_WriteRAM(0x05);
LCD_WriteRAM(0x00);

LCD_WriteCommand(0xE1); // Negative Gamma Correction
LCD_WriteRAM(0x00);
LCD_WriteRAM(0x25);
LCD_WriteRAM(0x27);
LCD_WriteRAM(0x05);
LCD_WriteRAM(0x10);
LCD_WriteRAM(0x09);
LCD_WriteRAM(0x3a);
LCD_WriteRAM(0x78);
LCD_WriteRAM(0x4d);
LCD_WriteRAM(0x05);
LCD_WriteRAM(0x18);
LCD_WriteRAM(0x0d);
LCD_WriteRAM(0x38);
LCD_WriteRAM(0x3a);
LCD_WriteRAM(0x1f);

//-----ddram-----
LCD_WriteCommand(0x2a); // Column Set
LCD_WriteRAM(0x00);
LCD_WriteRAM(0x00);
LCD_WriteRAM(0x00);
LCD_WriteRAM(0xEF);

LCD_WriteCommand(0x2b); // Page address set
LCD_WriteRAM(0x00);
LCD_WriteRAM(0x00);
LCD_WriteRAM(0x01);
LCD_WriteRAM(0x3F);

LCD_WriteCommand(0xb7); // Entry mode set
LCD_WriteRAM(0x07);

//-----Display-----
LCD_WriteCommand(0xb6); // Display function control
LCD_WriteRAM(0x0a);
LCD_WriteRAM(0x82);
LCD_WriteRAM(0x27);
LCD_WriteRAM(0x00);

```

```

LCD_WriteCommand(0x11); // Sleep out
delay_ms(100);

LCD_WriteCommand(0x29); // Display on
delay_ms(50);

LCD_WriteCommand(0x2a); // Column set
LCD_WriteRAM(0x00);
LCD_WriteRAM(0x00);
LCD_WriteRAM(0x00);
LCD_WriteRAM(0xEF);

LCD_WriteCommand(0x2b); // Page address set
LCD_WriteRAM(0x00);
LCD_WriteRAM(0x00);
LCD_WriteRAM(0x01);
LCD_WriteRAM(0x3F);

```

## 10 CAPACITIVE TOUCH SCREEN PANEL SPECIFICATIONS

### 10.1 Mechanical characteristics

DESCRIPTION	INL SPECIFICATION	REMARK
<b>Touch Panel Size</b>	2.83 inch	
<b>Outline Dimension (OD)</b>	49.5mm x 68.75mm	Cover Lens Outline
<b>Product Thickness</b>	1.675mm	
<b>Glass Thickness</b>	0.70mm	
<b>Ink View Area</b>	44.2mm x 58.6mm	
<b>Sensor Active Area</b>	45.20mm x 59.60mm	
<b>Input Method</b>	2 Fingers	
<b>Activation Force</b>	Touch	
<b>Surface Hardness</b>	≥6H	

### 10.2 Electrical characteristics

DESCRIPTION	SPECIFICATION	
Operating Voltage	DC 2.8~3.3V	
Power Consumption (IDD)	Active Mode	12~4.5mA
	Sleep Mode	TBD
Interface	I <sup>2</sup> C	
Controller	FT6236	
I2C address	0x38 (7-bit address)	
Resolution	240*320	

### 10.3 Interface description

PIN NO.	SYMBOL	DESCRIPTION	REMARK
1	VDD	Power supply	
2	/RES	Reset pin	
3	/INT	Interrupt signal from CTP	
4	SDA	I2C data signal	
5	SCK	I2C clock input	
6	GND	Ground	

10.4 Interface timing characteristics

PARAMETER	MIN	MAX	UNIT
SCL Frequency	0	400	kHz
Bus Free Time Between a STOP and START Condition	4.7	/	μs
Hold Time (repeated) START Condition	4.0	/	μs
Data Setup Time	250	/	ns
Setup Time for Repeated START Condition	4.7	/	μs
Setup Time for STOP Condition	4.0	/	μs

**Note:** For more information please go to IC specification.

10.5 CTP timing configuration

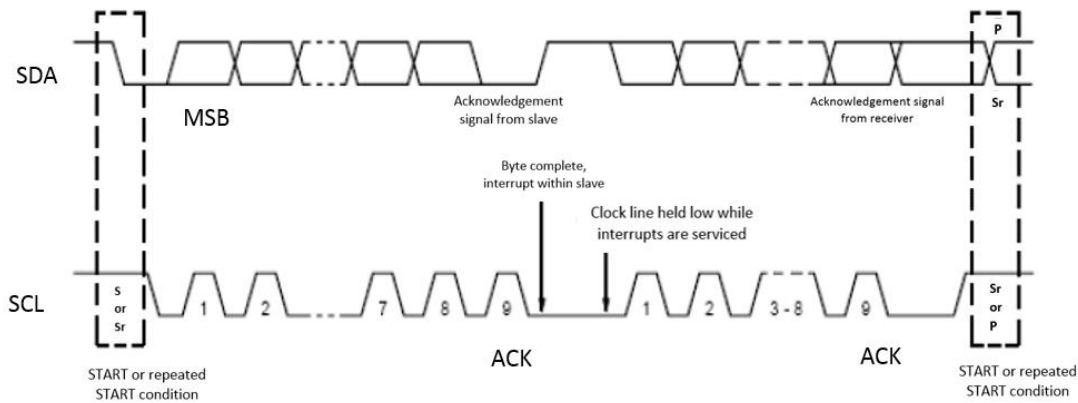

Figure 9. I2C master write, slave read

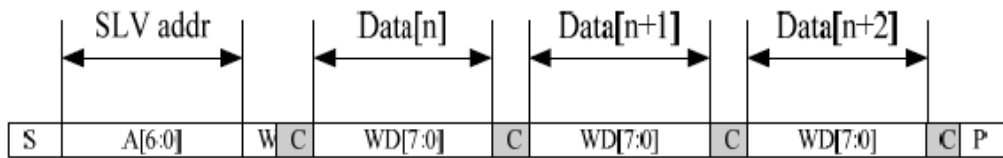
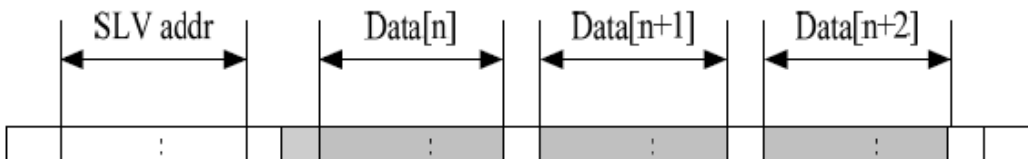

Figure 10. I2C master read, slave write



MNEMONICS	DESCRIPTIO
S	I2C Start or I2C Restart
A [6:0]	Slave address A [6:4]: 3'b011 A [3:0]: data bits are identical to those of I2CCON [7:4] register.
W	1'b0: Write
R	1'b0: Read
C	ACK
P	STOP: the indication of the end of a packet (if this bit is missing, S will indicate the end of the current packet and the beginning of the next packet)

10.6 Communication of the I2C interface with Host

Figure 11. Communication of the I2C interface with Host

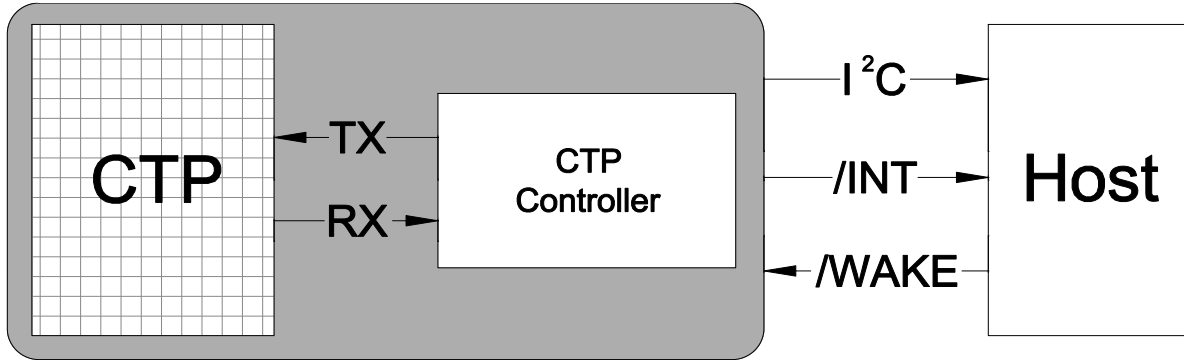

10.7 Touch data read protocol

ADDRESS	NAME	BIT 7	BIT 6	BIT 5	BIT 4	BIT 3	BIT 2	BIT 1	BIT 0	HOST ACCESS	
00h	DEVIDE_MODE	Device Mode [2:0]									RW
01h	GEST_ID	Gesture ID [7:0]								R	
02h	TD_STATUS					Number of touch points [3:0]				R	
03h	TOUCH1_XH	1 <sup>st</sup> Event Flag					1 <sup>st</sup> Touch X Position [11:8]			R	
04h	TOUCH1_XL	1 <sup>st</sup> Touch X Position [7:0]								R	
05h	TOUCH1_YH	1 <sup>st</sup> Touch ID [3:0]				1 <sup>st</sup> Touch X Position [11:8]				R	
06h	TOUCH1_YL	1 <sup>st</sup> Touch Y Position [7:0]								R	

10.8 Data description

DEVICE\_MODE

This register is the device mode register, configure it to determine the current mode of the chip.

ADDRESS	BIT ADDRESS	REGISTER NAME	DESCRIPTION
00h	6:4	Device Mode [2:0]	000b Work Mode 100b Factory Mode – Read Raw Data

GEST\_ID

This register describes the gesture of a valid touch.

ADDRESS	BIT ADDRESS	REGISTER NAME	DESCRIPTION
01h	7:0	Gesture ID [7:0]	Gesture ID 0x10 Move Up 0x14 Move Down 0x18 Move Right 0x48 Zoom In 0x49 Zoom Out 0x00 No Gesture

**TD\_STATUS**

This register is the Touch Data status register.

ADDRESS	BIT ADDRESS	REGISTER NAME	DESCRIPTION
02h	3:0	Number of Touch Points [2:0]	How Many Points Detected 1-5 is Valid
	7:4		

**TOUCHn\_XH(n:1-10)**

This register describes MSB of the X coordinate of the nth touch point and the corresponding event flag.

ADDRESS	BIT ADDRESS	REGISTER NAME	DESCRIPTION
03h ~ 39h	7:6	Event Flag	00b: Put Down
			01b: Put Up
	5:4		Reserved
	3:0	Touch X Position [11:8]	MSB of Touch X Position in Pixels

**TOUCHn\_XL(n:1-10)**

This register describes LSB of the X coordinate of the nth touch point.

ADDRESS	BIT ADDRESS	REGISTER NAME	DESCRIPTION
04h ~ 3Ah	7:0	Touch X Position [7:0]	LSB of the Touch X Position in Pixels

**TOUCHn\_YH(n:1-10)**

This register describes MSB of the Y coordinate of the nth touch point and corresponding touch ID.

ADDRESS	BIT ADDRESS	REGISTER NAME	DESCRIPTION
05h ~ 3Bh	7:4	Touch ID[3:0]	Touch ID of Touch Point
	3:0	Touch X Position [11:8]	MSB of Touch Y Position in Pixels

**TOUCHn\_YL(n:1-10)**

This register describes LSB of the Y coordinate of the nth touch point.

ADDRESS	BIT ADDRESS	REGISTER NAME	DESCRIPTION
05h ~ 3Bh	7:0	Touch X Position [7:0]	LSB of the Touch Y Position in Pixels

10.9 Interrupt Trigger Mode

Figure 12. Interrupt trigger mode timing

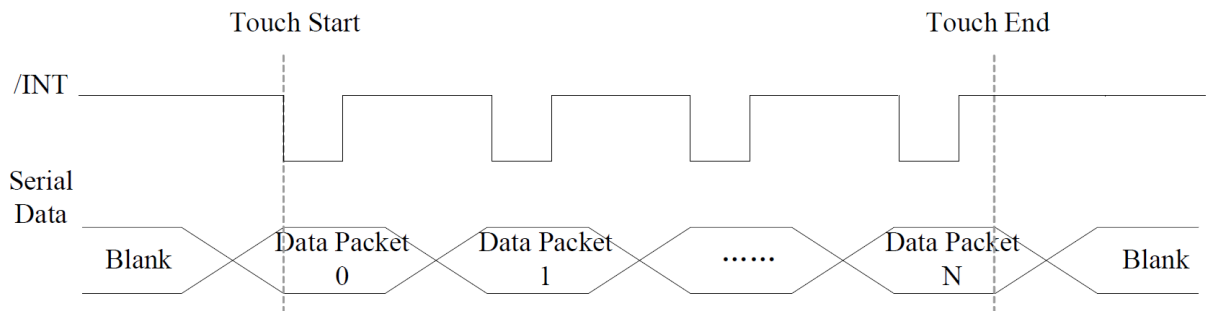

## 11 INSPECTION

Standard acceptance/rejection criteria for TFT module.

### 11.1 Inspection condition

*Ambient conditions:*

- Temperature:  $25\pm^{\circ}\text{C}$
- Humidity:  $(60\pm 10)\% \text{RH}$
- Illumination: Single fluorescent lamp non-directive (300 to 700 lux)

*Viewing distance:*

$35\pm 5\text{cm}$  between inspector bare eye and LCD.

*Viewing Angle:*

U/D:  $45^{\circ}/45^{\circ}$ , L/R  $45^{\circ}/45^{\circ}$

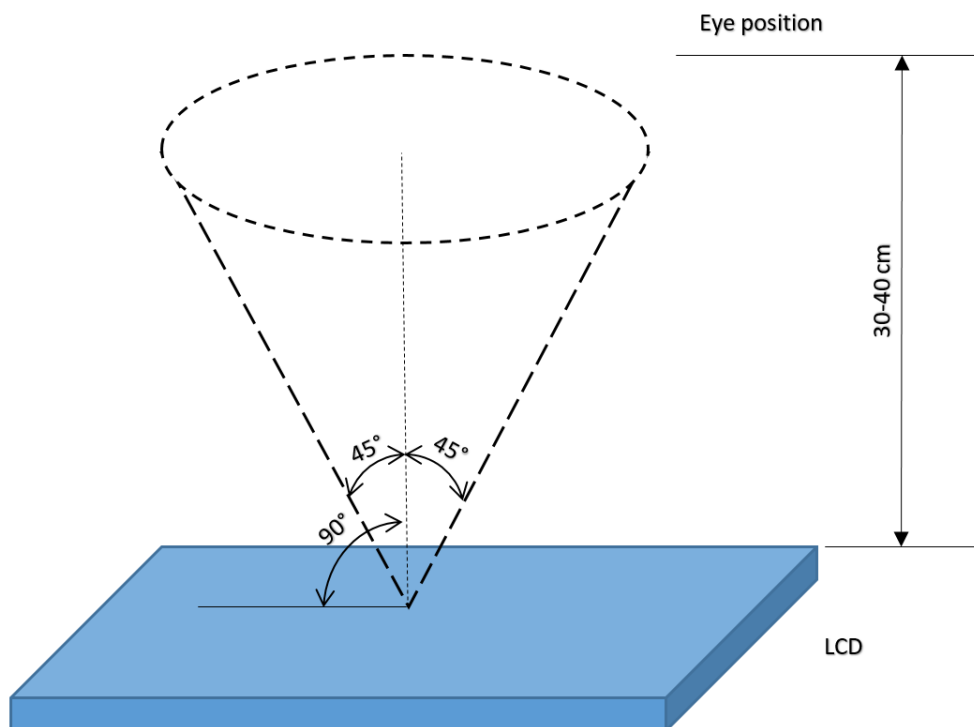

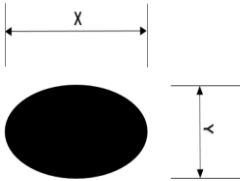
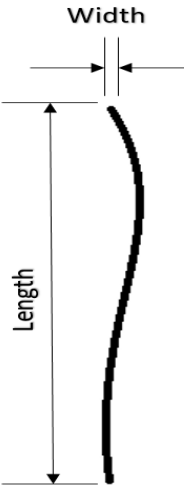

11.2 Inspection standard

Item	Criterion																																		
<p><b>Black spots, white spots, light leakage, Foreign Particle (round Type)</b></p>	<div style="display: flex; align-items: center; justify-content: center;">  <table border="1" style="margin-left: 20px;"> <thead> <tr> <th colspan="2">Size &lt; 5"</th> </tr> <tr> <th>Average Diameter</th> <th>Qualified Qty</th> </tr> </thead> <tbody> <tr> <td>D &lt; 0.2 mm</td> <td>Ignored</td> </tr> <tr> <td>0.2 mm &lt; D &lt; 0.3 mm</td> <td>3</td> </tr> <tr> <td>0.3 mm &lt; D &lt; 0.5 mm</td> <td>2</td> </tr> <tr> <td>0.5 mm &lt; D</td> <td>0</td> </tr> </tbody> </table> </div> <div style="text-align: center; margin: 10px 0;"> <math display="block">D = \frac{(x + y)}{2}</math> </div> <p>*Spots density: 10 mm</p>	Size < 5"		Average Diameter	Qualified Qty	D < 0.2 mm	Ignored	0.2 mm < D < 0.3 mm	3	0.3 mm < D < 0.5 mm	2	0.5 mm < D	0																						
Size < 5"																																			
Average Diameter	Qualified Qty																																		
D < 0.2 mm	Ignored																																		
0.2 mm < D < 0.3 mm	3																																		
0.3 mm < D < 0.5 mm	2																																		
0.5 mm < D	0																																		
<p><b>LCD black spots, white spots, light leakage (line Type)</b></p>	<div style="display: flex; align-items: center; justify-content: center;">  <table border="1" style="margin-left: 20px;"> <thead> <tr> <th colspan="3">Size &lt; 5"</th> </tr> <tr> <th>Length</th> <th>Width</th> <th>Qualified Qty</th> </tr> </thead> <tbody> <tr> <td>-</td> <td>W &lt; 0.02</td> <td>Ignored</td> </tr> <tr> <td>L &lt; 3.0</td> <td>0.02 &lt; W &lt; 0.05</td> <td rowspan="2">2</td> </tr> <tr> <td>L &lt; 2.5</td> <td>0.05 &lt; W &lt; 0.08</td> </tr> <tr> <td>-</td> <td>0.08 &lt; W</td> <td>0</td> </tr> </tbody> </table> </div> <div style="margin: 10px 0;"> <table border="1" style="margin-left: auto; margin-right: auto;"> <thead> <tr> <th colspan="3">Size &gt;= 5"</th> </tr> <tr> <th>Length</th> <th>Width</th> <th>Qualified Qty</th> </tr> </thead> <tbody> <tr> <td>-</td> <td>W &lt; 0.02</td> <td>Ignored</td> </tr> <tr> <td>L &lt; 3.0</td> <td>0.02 &lt; W &lt; 0.05</td> <td rowspan="2">4</td> </tr> <tr> <td>L &lt; 2.5</td> <td>0.05 &lt; W &lt; 0.08</td> </tr> <tr> <td>-</td> <td>0.08 &lt; W</td> <td>0</td> </tr> </tbody> </table> </div> <p>*Spots density: 10 mm</p>	Size < 5"			Length	Width	Qualified Qty	-	W < 0.02	Ignored	L < 3.0	0.02 < W < 0.05	2	L < 2.5	0.05 < W < 0.08	-	0.08 < W	0	Size >= 5"			Length	Width	Qualified Qty	-	W < 0.02	Ignored	L < 3.0	0.02 < W < 0.05	4	L < 2.5	0.05 < W < 0.08	-	0.08 < W	0
Size < 5"																																			
Length	Width	Qualified Qty																																	
-	W < 0.02	Ignored																																	
L < 3.0	0.02 < W < 0.05	2																																	
L < 2.5	0.05 < W < 0.08																																		
-	0.08 < W	0																																	
Size >= 5"																																			
Length	Width	Qualified Qty																																	
-	W < 0.02	Ignored																																	
L < 3.0	0.02 < W < 0.05	4																																	
L < 2.5	0.05 < W < 0.08																																		
-	0.08 < W	0																																	



Item	Criterion	
Clear spots	Size < 5"	
	<b>Average Diameter</b>	Qualified Qty
	<b>D &lt; 0.2 mm</b>	Ignored
	<b>0.2 mm &lt; D &lt; 0.3 mm</b>	3
	<b>0.3 mm &lt; D &lt; 0.5 mm</b>	2
	<b>0.5 mm &lt; D</b>	0
	Size >= 5"	
	<b>Average Diameter</b>	Qualified Qty
	<b>D&lt;0.2 mm</b>	Ignored
	<b>0.2 mm &lt; D &lt; 0.3 mm</b>	4
	<b>0.3 mm &lt; D &lt; 0.5 mm</b>	2
	<b>0.5 mm &lt; D</b>	0
	*Spots density: 10 mm	
	Polarizer bubbles	Size < 5"
<b>Average Diameter</b>		Qualified Qty
<b>D &lt; 0.2 mm</b>		Ignored
<b>0.2 mm &lt; D &lt; 0.5 mm</b>		3
<b>0.5 mm &lt; D &lt; 1 mm</b>		2
<b>1 mm &lt; D</b>		0
<b>Total Q'ty</b>		3
Size >= 5"		
<b>Average Diameter</b>		Qualified Qty
<b>D&lt;0.25 mm</b>		Ignored
<b>0.25 mm &lt; D &lt; 0.5 mm</b>		3
<b>0.5 mm &lt; D</b>		0
Electrical Dot Defect		Size < 5"
		<b>item</b>
	<b>Black do defect</b>	4
	<b>Bright dot defect</b>	2
	<b>Total Dot</b>	5
	Size >= 5"	
	<b>item</b>	Qualified Qty
	<b>Black do defect</b>	5
	<b>Bright dot defect</b>	2
	<b>Total Dot</b>	5

Item	Criterion		
Touch panel spot	Size < 5"		
	<b>Average Diameter</b>	Qualified Qty	
	<b>D &lt; 0.2 mm</b>	Ignored	
	<b>0.2 mm &lt; D &lt; 0.4 mm</b>	5	
	<b>0.4 mm &lt; D &lt; 0.5 mm</b>	2	
	<b>0.5 mm &lt; D</b>	0	
	Size >= 5"		
	<b>Average Diameter</b>	Qualified Qty	
	<b>D &lt; 0.25 mm</b>	Ignored	
	<b>0.25 mm &lt; D &lt; 0.5 mm</b>	4	
<b>0.5 mm &lt; D</b>	0		
Touch panel White Line Scratch	Size < 5"		
	<b>Length</b>	<b>Width</b>	Qualified Qty
	-	W < 0.02	Ignored
	<b>L &lt; 3.0</b>	0.02 < W < 0.05	2
	<b>L &lt; 2.5</b>	0.05 < W < 0.08	
	-	0.08 < W	0
	Size >= 5"		
	<b>Length</b>	<b>Width</b>	Qualified Qty
	-	W < 0.03	Ignored
	<b>L &lt; 5.0</b>	0.03 < W < 0.05	2
-	0.05 < W	0	

## 12 RELIABILITY TEST

NO.	TEST ITEM	TEST CONDITION	INSPECTION AFTER TEST
1	High Temperature Storage	80±2°C/96 hours	Inspection after 2~4 hours storage at room temperature and humidity. The condensation is not accepted. The sample shall be free from defects:  1. Air bubble in the LCD 2. Seal leak 3. Non-display 4. Missing segments 5. Glass crack
2	Low Temperature Storage	-30±2°C/96 hours	
3	High Temperature Operating	70±2°C/96 hours	
4	Low Temperature Operating	-20±2°C/96 hours	
5	Temperature Cycle	-30±2°C ~ 25~ 80± 2°C × 10 cycles (30 min.) (5min.) (30min.)	
6	Damp Proof Test	60°C ±5°C × 90%RH/96 hours	
7	Vibration Test	Frequency 10Hz~55Hz Stroke: 1.5mm Sweep: 10Hz~150 Hz~10Hz 2 hours For each direction of X, Y, Z	
8	Shock Test	Half-sine, wave, 300m/s	
9	Packing Drop Test	Height: 80 cm 1 corner, concrete floor	
11	Electrostatic Discharge Test	C=150pF, R=330 Ω Air: ±8KV 150pF/330Ω 30 times Contact: ±4KV,20 times	

## 13 LEGAL INFORMATION

Riverdi makes no warranty, either expressed or implied with respect to any product, and specifically disclaims all other warranties, including, without limitation, warranties for merchantability, non-infringement and fitness for any particular purpose. Information about device are the property of Riverdi and may be the subject of patents pending or granted. It is not allowed to copy or disclosed this document without prior written permission.

Riverdi endeavors to ensure that the all contained information in this document are correct but does not accept liability for any error or omission. Riverdi products are in developing process and published information may be not up to date. Riverdi reserves the right to update and makes changes to Specifications or written material without prior notice at any time. It is important to check the current position with Riverdi.

Images and graphics used in this document are only for illustrative the purpose. All images and graphics are possible to be displayed on the range products of Riverdi, however the quality may vary. Riverdi is no liable to the buyer or to any third part for any indirect, incidental, special, consequential, punitive or exemplary damages (including without limitation lost profits, lost savings, or loss of business opportunity) relating to any product, service provided or to be provided by Riverdi, or the use or inability to use the same, even if Riverdi has been advised of the possibility of such damages.

Riverdi products are not fault tolerant nor designed, manufactured or intended for use or resale as on line control equipment in hazardous environments requiring fail – safe performance, such as in the operation of nuclear facilities, aircraft navigation or communication systems, air traffic control, direct life support machines or weapons systems in which the failure of the product could lead directly to death, personal injury or severe physical or environmental damage ('High Risk Activities'). Riverdi and its suppliers specifically disclaim any expressed or implied warranty of fitness for High Risk Activities. Using Riverdi products and devices in 'High Risk Activities' and in any other application is entirely at the buyer's risk, and the buyer agrees to defend, indemnify and hold harmless Riverdi from any and all damages, claims or expenses resulting from such use. No licenses are conveyed, implicitly or otherwise, under any Riverdi intellectual property rights.

