

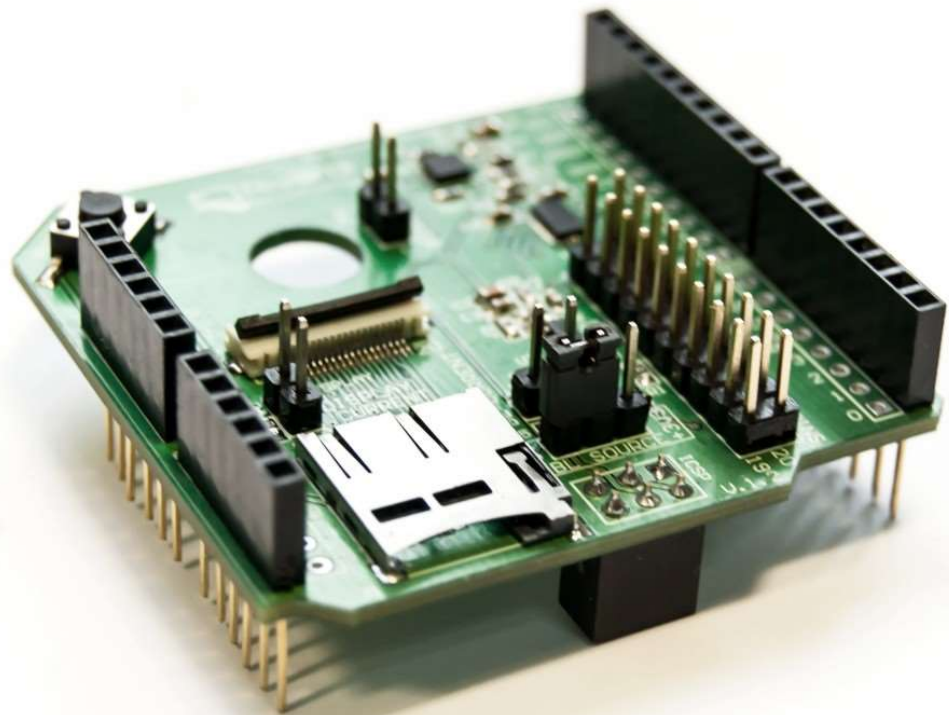

Arduino Riverdi TFT shield

User Manual

Rev.1.2
2015-12-17





REVISION RECORD

REVNO.	REVDATE	CONTENTS	REMARKS
1.0	2015-06-30	Initial Release	
1.1	2015-12-17	Add development kit information	
1.2	2016-04-08	Updated schematics	

CONTENTS

REVISION RECORD.....	2
CONTENTS	2
1. INTRODUCTION	3
2. DEVELOPMENT KIT SET.....	3
3. DESCRIPTION	4
3.1 Board description	4
3.2 Display ZIF connector	5
3.3 Multiple display pin headers (CN2)	7
3.4 External speaker connector (CN1).....	7
3.5 Micro-SD card slot (J1).....	7
3.6 Backlight power supply selection jumper (CN4)	7
3.7 Current measure headers.....	7
4. MECHANICAL DRAWING	8
5. ELECTRICAL SCHEMATIC.....	9
6. TFT DISPLAY CONNECTION	10
7. LEGAL INFORMATION.....	11

1. INTRODUCTION

The Arduino Riverdi TFT shield allows to connect Arduino with Riverdi TFT displays with FT80x and FT81x chips.

This Arduino shield contains external speaker connector. On the board is also micro – SD card slot, which can be used to store graphics or music. There is a Reset button which can be used for reset Arduino.

Visit <https://riverdi.com/product/arduino-riverdi-tft-shield/> to see the examples of using The Riverdi Eve Arduino Shield.

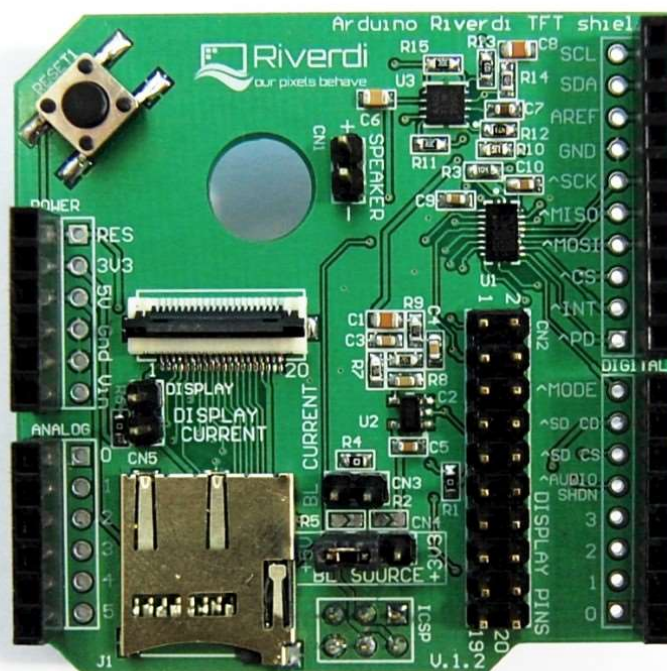

2. DEVELOPMENT KIT SET

Arduino Riverdi kit contains:

- Arduino Riverdi TFT shield board,
- 20 pin, 0.5mm, 15 cm length FFC

3. DESCRIPTION

3.1 Board description

The Arduino Riverdi TFT shield contains:

- Display ZIF connector (20 pin)
- Multiple display pin headers
- External speaker connector
- Micro-SD card slot
- Backlight power supply selection jumper
- Reset button

Figure 1 shows The Arduino Riverdi TFT shield significant parts.

Figure 1. The Riverdi EVE Arduino Shield –parts

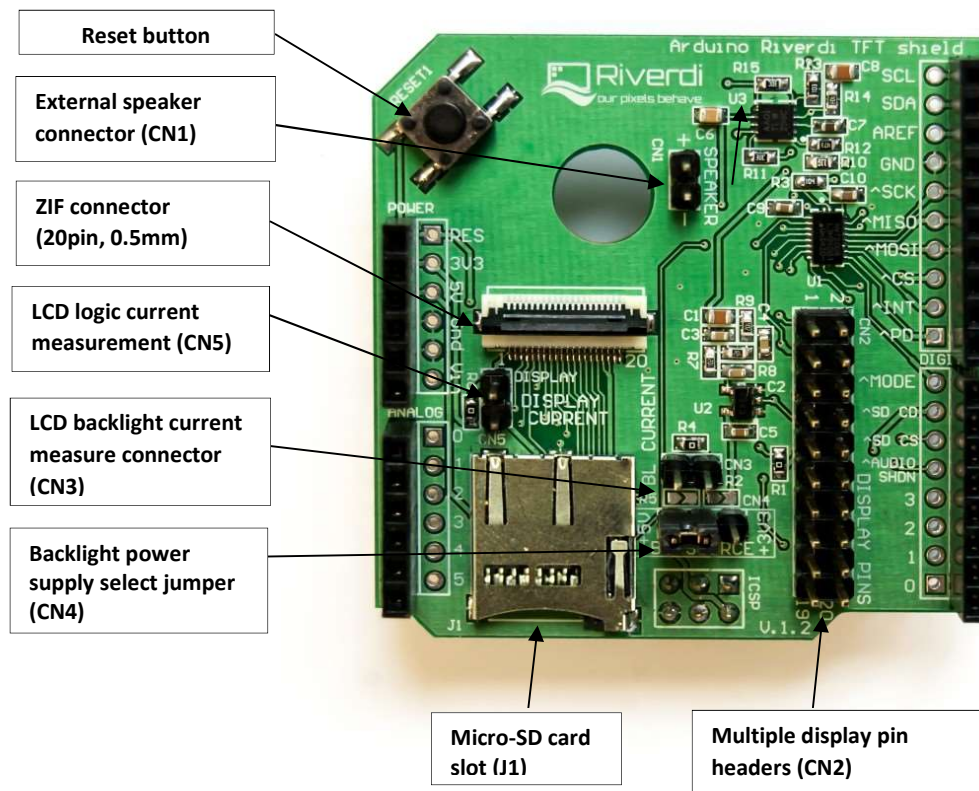

3.2 Display ZIF connector

TFT module is connected to Arduino Shield with DISPLAY CONNECTOR (ZIF, 20 pin, 0.5mm). Pin description depends on the display module type. There are two types. One of them is for displays with FT80x controllers, other one is for displays with FT81x controllers. The tables below describe pins of display connectors and show their connection to Arduino. To check which controller is used in TFT module model refer to a specific datasheet on <http://riverdi.com/products/>.

Table 1. PIN description for FT80x

PIN NO	SYMBOL	ARDUINO PIN	DESCRIPTION
1	VDD	3V3	Power Supply
2	GND	GND	Ground
3	SPI_SCLK/ I2C_SCL	SCK	SPI SCK Signal / I2C SCL Signal, Internally 47k Pull UP
4	MISO/ I2C_SDA	MISO	SPI MISO Signal / I2C SDA Signal, Internally 47k Pull UP
5	MOSI/ I2C_SA0	MOSI	SPI MOSI Signal / I2C Slave Address Bit 0, Internally 47k Pull UP
6	CS/I2C_SA1	D10	SPI Chip Select Signal / I2C Slave Address Bit 1, Internally 47k Pull UP
7	INT	D9	Interrupt Signal, Active Low, Internally 47k Pull UP
8	PD	D8	Power Down Signal, Active Low, Internally 47k Pull UP
9	MODE	D7	Host Interface SPI(Pull Low) or I2C(Pull Up) Mode Select Input, Internally 10k Pull DOWN
10	AUDIO_OUT	-	Audio Out Signal
11	NC	-	Not Connected
12	NC	-	Not Connected
13	NC	-	Not Connected
14	NC	-	Not Connected
15	NC	-	Not Connected
16	NC	-	Not Connected
17	BLVDD	-	Backlight Power Supply, Can Be Connected to VDD
18	BLVDD	-	Backlight Power Supply, Can Be Connected to VDD
19	BLGND	-	Backlight Ground, Internally connected to GND
20	BLGND	-	Backlight Ground, Internally connected to GND



Table 2. PIN description for FT81x

PIN NO	SYMBOL	ARDUINO PIN	DESCRIPTION
1	VDD	3V3	Power Supply
2	GND	GND	Ground
3	SPI_SCLK	SCK	SPI SCK Signal, Internally 47k Pull UP
4	MISO/ IO0	MISO	SPI MISO Signal / IO0 Signal, Internally 47k Pull UP
5	MOSI/ IO1	MOSI	SPI MOSI Signal / IO1 Slave Address Bit 0, Internally 47k Pull UP
6	CS	D10	SPI Chip Select Signal , Internally 47k Pull UP
7	INT	D9	Interrupt Signal, Active Low, Internally 47k Pull UP
8	PD	D8	Power Down Signal, Active Low, Internally 47k Pull UP
9	NC	D7	Not Connected
10	AUDIO_OUT	-	Audio Out Signal
11	GPIO0/IO2	-	SPI Single mode: General purpose IO0/ SPI Quad mode: SPI data line 2
12	GPIO1/IO3	-	SPI Single mode: General purpose IO1/ SPI Quad mode: SPI data line 3
13	GPIO2	-	General purpose IO2
14	GPIO3	-	General purpose IO3 or analog input for ADC
15	NC	-	Not Connected
16	NC	-	Not Connected
17	BLVDD	-	Backlight Power Supply, Can Be Connected to VDD
18	BLVDD	-	Backlight Power Supply, Can Be Connected to VDD
19	BLGND	-	Backlight Ground, Internally connected to GND
20	BLGND	-	Backlight Ground, Internally connected to GND

3.3 Multiple display pin headers (CN2)

The Arduino Riverdi TFT shield allows to expand Riverdi TFT module pins to user friendly 2.54 mm pin headers. The multiple display pin headers are designed for TFT modules with FT80x and FT81x controllers.

3.4 External speaker connector (CN1)

The external speaker connector (CN1) is used for connecting external speaker 8 Ohm and 1W. Amplifier Circuit schematic is presented in ELECTRICAL SCHEMATIC section. Amplifier circuit can be muted by AUDIO SHUTDOWN pin connected to DIGITAL PIN 4.

3.5 Micro-SD card slot (J1)

The micro-SD slot allows to connect micro-SD card. The stored data can be used by Arduino. The Arduino communicates with both micro-SD and Riverdi TFT display via SPI.

Micro-SD card Chip Select is available on DIGITAL PIN 5 and Micro-SD Card Detection Signal is available on DIGITAL PIN 6.

3.6 Backlight power supply selection jumper (CN4)

Riverdi TFT modules has independent backlight power supply module. The backlight power supply can be 3.3V or 5V and it is selected on CN4.

3.7 Current measure headers

In the Arduino Riverdi TFT shield you can measure the current consumption of LCD logic and backlight inverter. LCD logic current consumption can be measured on CN5. Backlight inverter logic can be measured on CN3. By default CN5 is short circuited with R6 and CN3 is short circuited with R4. Current measure is available after unsoldering mentioned resistors.

4. MECHANICAL DRAWING

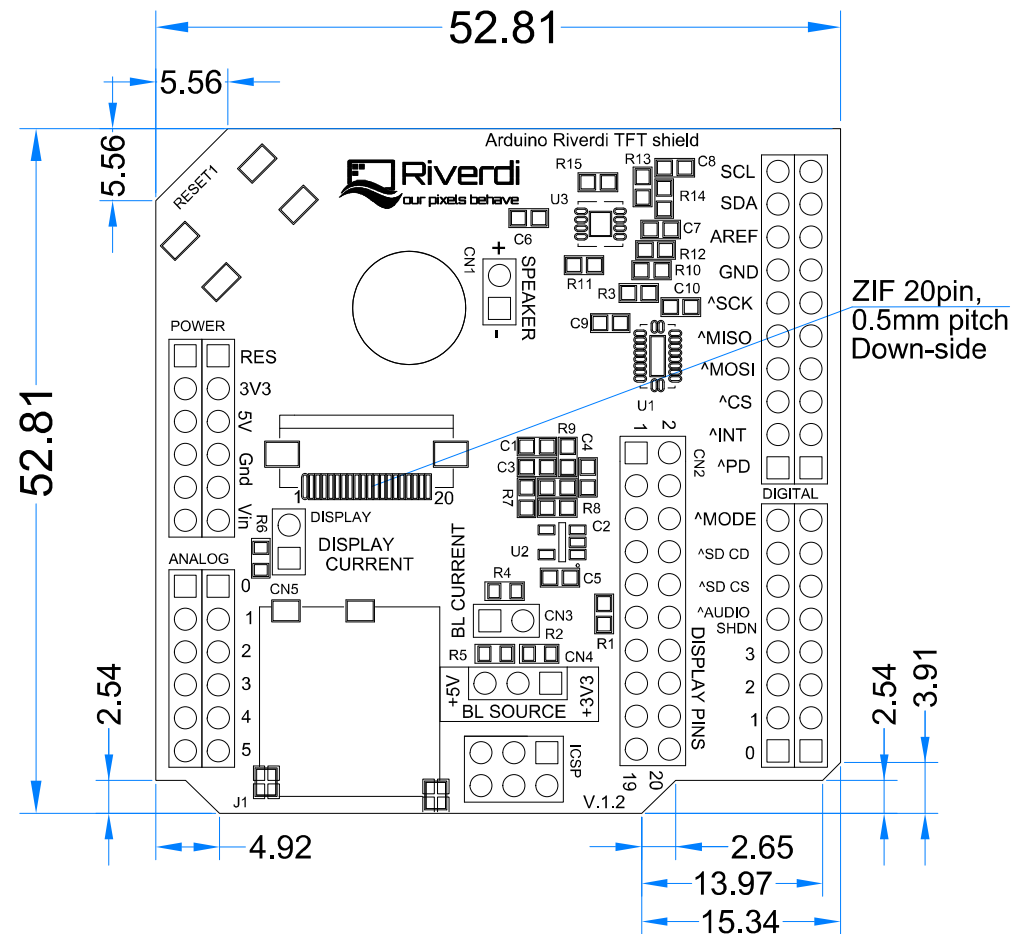

5. ELECTRICAL SCHEMATIC

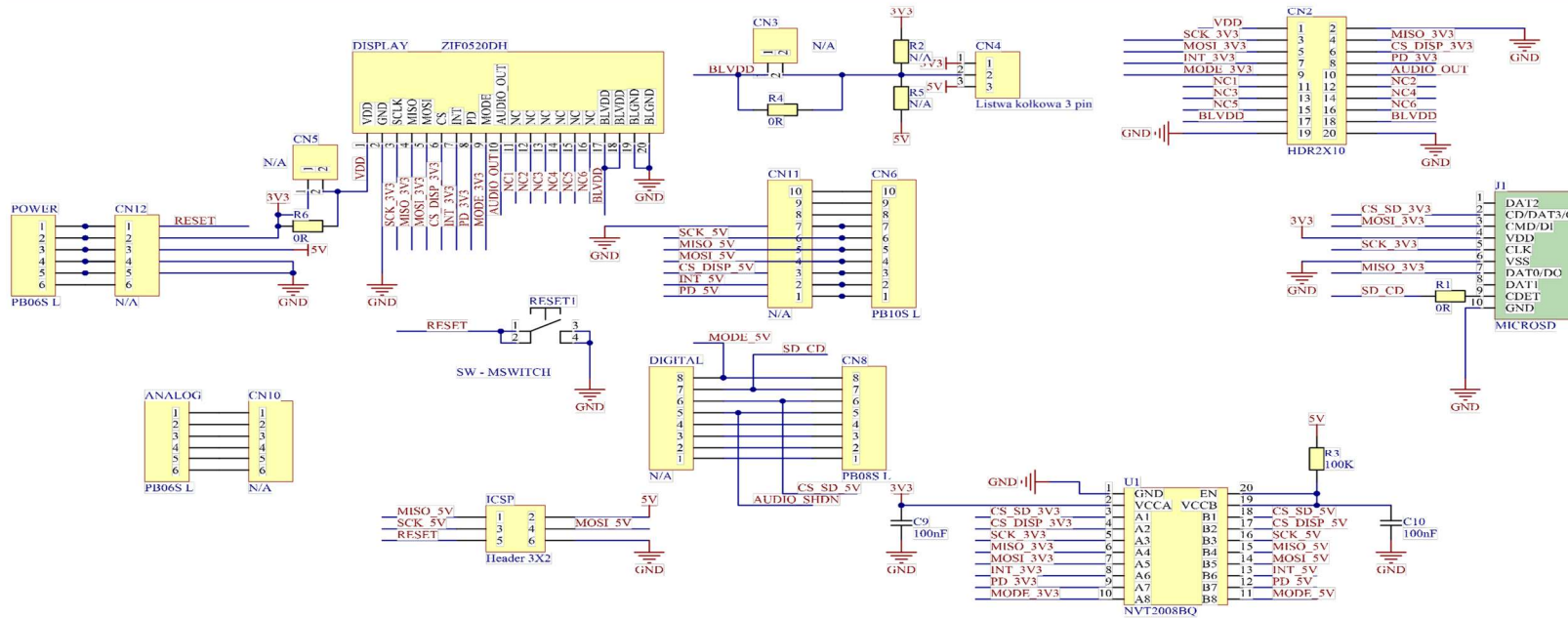
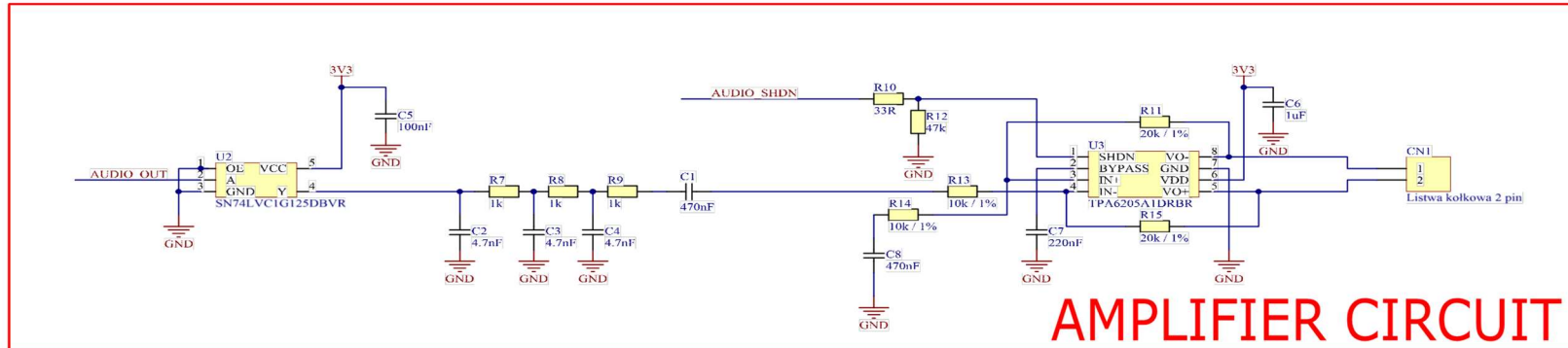

6. TFT DISPLAY CONNECTION

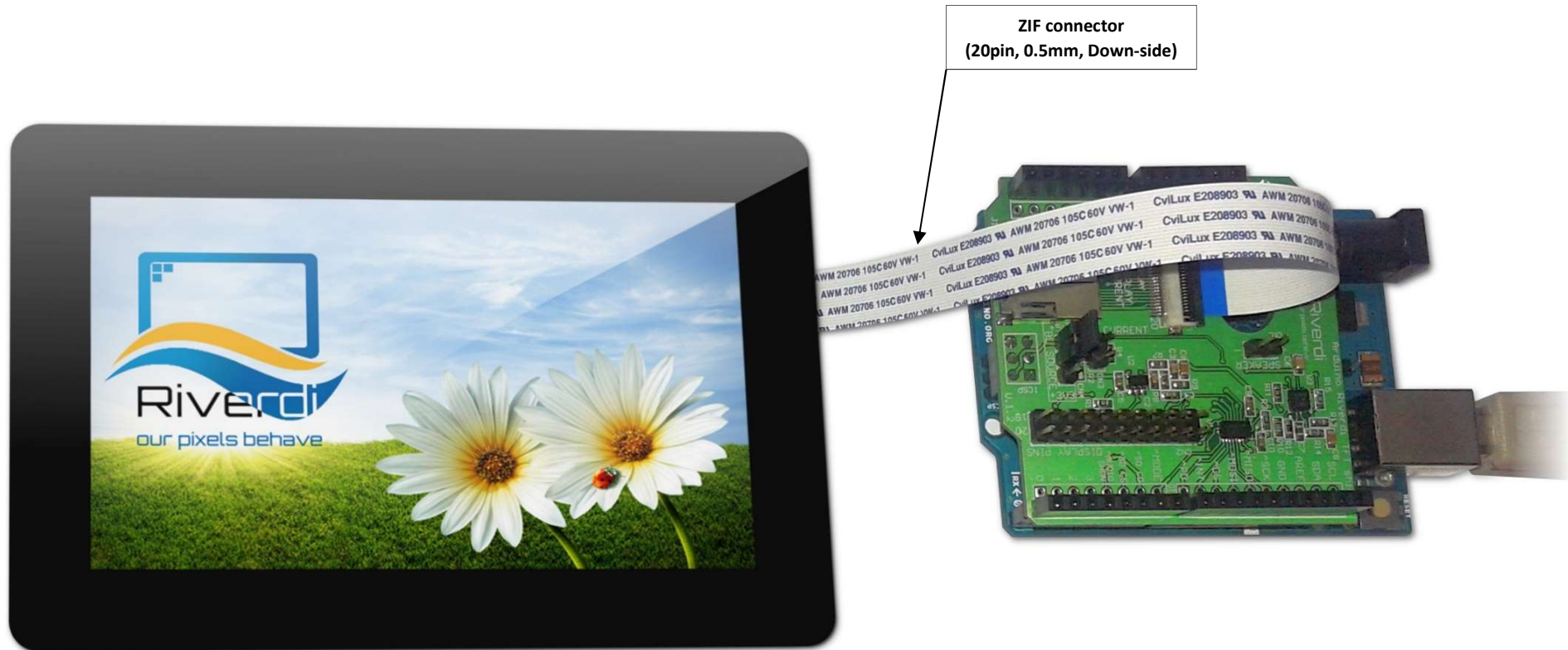

7. LEGAL INFORMATION

Riverdi makes no warranty, either expressed or implied with respect to any product, and specifically disclaims all other warranties, including, without limitation, warranties for merchantability, non-infringement and fitness for any particular purpose. Information about device are the property of Riverdi and may be the subject of patents pending or granted. It is not allowed to copy or disclosed this document without prior written permission.

Riverdi endeavors to ensure that the all contained information in this document are correct but does not accept liability for any error or omission. Riverdi products are in developing process and published information may be not up to date. Riverdi reserves the right to update and makes changes to Specifications or written material without prior notice at any time. It is important to check the current position with Riverdi.

Images and graphics used in this document are only for illustrative the purpose. All images and graphics are possible to be displayed on the range products of Riverdi, however the quality may vary. Riverdi is no liable to the buyer or to any third part for any indirect, incidental, special, consequential, punitive or exemplary damages (including without limitation lost profits, lost savings, or loss of business opportunity) relating to any product, service provided or to be provided by Riverdi, or the use or inability to use the same, even if Riverdi has been advised of the possibility of such damages.

Riverdi products are not fault tolerant nor designed, manufactured or intended for use or resale as on line control equipment in hazardous environments requiring fail – safe performance, such as in the operation of nuclear facilities, aircraft navigation or communication systems, air traffic control, direct life support machines or weapons systems in which the failure of the product could lead directly to death, personal injury or severe physical or environmental damage ('High Risk Activities'). Riverdi and its suppliers specifically disclaim any expressed or implied warranty of fitness for High Risk Activities. Using Riverdi products and devices in 'High Risk Activities' and in any other application is entirely at the buyer's risk, and the buyer agrees to defend, indemnify and hold harmless Riverdi from any and all damages, claims or expenses resulting from such use. No licenses are conveyed, implicitly or otherwise, under any Riverdi intellectual property rights.

